



PVC and CPVC

SB Series Simplex Basket Strainers

1/2" TO 4" PVC, CPVC, GFPP BLACK, GFPP PLATINUM AND EASTAR®

KEY FEATURES

- PVC, CPVC, GFPP and Eastar®
- True Union
- Ergonomic Hand-Removable Cover
- In-Line or Loop Connections
- External Cover Threads
- Integral Flat Mounting Bases
- PVC or CPVC Baskets Standard
- NSF/ANSI 61 Listed

OPTIONS

- Stainless Steel, Monel®, Hastelloy® and Titanium Strainer Baskets
- Pressure Differential Gauge and Switch
- Baskets Available with Perforated or Mesh Liners

MATERIALS

- PVC Cell Class 12454 per ASTM D1784
- CPVC Cell Class 23447 per ASTM D1784
- GFPP Cell Class 85580 per ASTM D4101
- Eastar®
- FPM and EPDM O-Ring Seals

TECHNICAL INFORMATION

EXPLODED VIEW

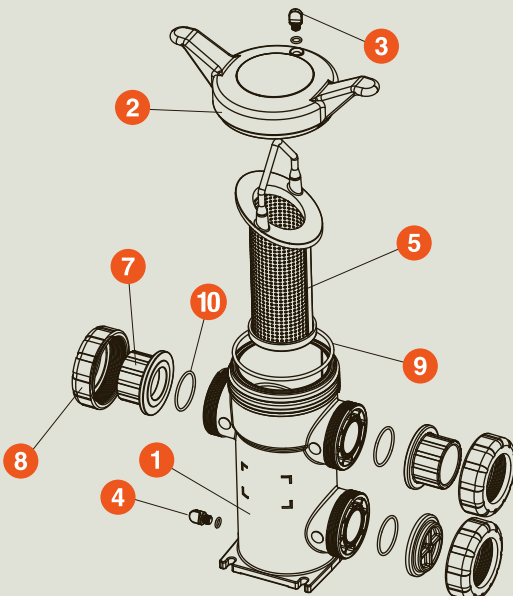

SELECTION CHART

SIZE	MATERIAL	END CONNECTION	SEALS	PRESSURE RATING
1/2" – 4" (DN15 – DN100)	PVC or CPVC	Socket, Threaded or Flanged	FPM or EPDM	150 PSI @ 70°F Non-Shock
	Eastar®*			100 PSI @ 70°F Non-Shock
	GFPP	Threaded or Flanged		150 PSI @ 70°F Non-Shock

* End connections and assembly nuts are PVC

SB Series Simplex Basket Strainers

1/2" TO 4" PVC, CPVC, GFPP AND EASTAR®



www.monarchindustrial.com.au
www.monarchasiapacific.com.au

TECHNICAL INFORMATION, CONTINUED

PARTS LIST

1. Body
2. Cover
3. Vent Plug and O-Ring
4. Drain Plug and O-Ring
5. Basket
6. Flange (Optional)
7. End Connector
8. Nut
9. Cover O-Ring
10. End Connector O-Ring

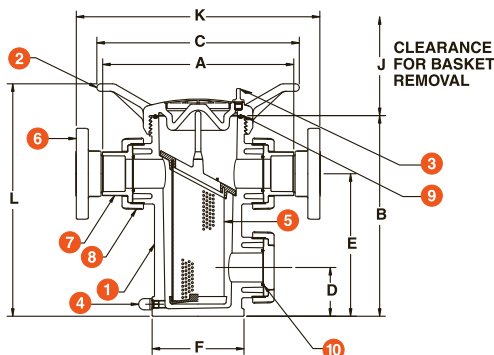

OPERATING TEMPERATURE/PRESSURE

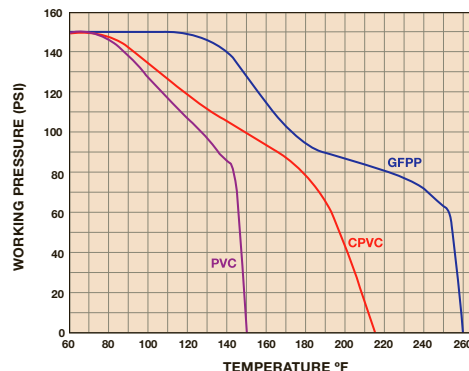

DIMENSIONS

SIZE in/DN	A in/mm	B in/mm	C in/mm	D in/mm	E in/mm	F in/mm	J in/mm	K in/mm	L in/mm	WEIGHT lbs/kg		VOLUME gal/LT
										SOC/THD	FLANGED	
1/2/15	8.64/219	9.63/245	11.00/279	2.25/57	6.75/171	4.31/109	8.00/203	10.77/274	11.70/297	8.00/3.63	9.00/4.08	.20/.76
3/4/20	8.64/219	9.63/245	11.00/279	2.25/57	6.75/171	4.31/109	8.00/203	11.02/280	11.70/297	8.00/3.63	9.00/4.08	.20/.76
1/25	8.64/219	9.63/245	11.00/279	2.25/57	6.75/171	4.31/109	8.00/203	11.64/296	11.70/297	8.00/3.63	9.00/4.08	.20/.76
1-1/4/32	12.75/324	13.38/340	13.50/343	3.25/83	9.50/241	6.13/156	12.86/327	15.63/397	15.50/394	14.00/6.35	16.50/7.48	.70/2.65
1-1/2/40	12.69/322	13.38/340	13.50/343	3.25/83	9.50/241	6.13/156	12.86/327	15.89/403	15.50/394	14.00/6.35	16.50/7.48	.70/2.65
2/50	12.75/324	13.38/340	13.50/343	3.25/83	9.50/241	6.13/156	12.86/327	16.29/413	15.50/394	14.00/6.35	16.50/7.48	.70/2.65
2-1/2/65	16.52/420	19.83/504	16.00/406	4.83/123	14.83/377	7.25/184	17.25/438	21.02/534	22.30/566	28.00/12.70	33.00/14.97	2.80/10.60
3/80	16.40/417	19.83/504	16.00/406	4.83/123	14.83/377	7.25/184	17.25/438	20.36/517	22.30/566	28.00/12.70	33.50/15.20	2.80/10.60
4/100	17.27/439	19.83/504	16.00/406	4.83/123	14.83/377	7.25/184	17.25/438	22.13/562	22.30/566	28.00/12.70	37.00/16.78	2.80/10.60

Dimensions are subject to change without notice – consult factory for installation information

PRESSURE DROP CALCULATIONS

BASKET PERFORATION CORRECTION FACTORS

For 1/2" to 4" Strainers

Plastic		Stainless Steel	
1/32"	1.05	1/32"	.82
1/16"	1.00	20 Mesh	.79
1/8"	.58	40 Mesh	1.01
3/16"	.46	60 Mesh	1.20
		80 Mesh	1.16
		100 Mesh	1.20
		200 Mesh	1.09
		325 Mesh	1.22

PRESSURE LOSS CALCULATION FORMULA

The pressure drop across the strainer, for water or fluids with a similar viscosity, can be calculated using the formula at the right:

$$\Delta P = \left[\frac{Q}{C_v} \right]^2$$

ΔP = Pressure Drop
Q = Flow in GPM
Cv = Flow Coefficient

Cv VALUES

SIZE in/DN	Cv VALUES	SIZE in/DN	Cv VALUES
1/2/15	15	2/50	60
3/4/20	18	2-1/2/65	290
1/25	20	3/80	300
1-1/4/32	55	4/100	350
1-1/2/40	58		

The above Cv Values were determined using a 1/16" perforated plastic basket in 1/2" through 4" strainers.

To calculate pressure drop through vessels using other than 1/16" perforated baskets, first calculate the pressure drop using the listed Cv, and then multiply the result by the correction factor in the Correction Factors chart to the left.