

HAYWARD FLOW CONTROL

1/4" – 2", TB SERIES TRUE UNION BALL VALVE

INSTALLATION, OPERATION AND MAINTENANCE INSTRUCTIONS

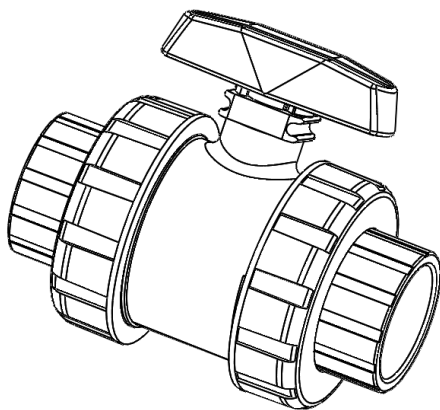

PLEASE READ THE FOLLOWING INFORMATION PRIOR TO INSTALLING AND USING HAYWARD TB SERIES BALL VALVES. FAILURE TO FOLLOW THESE INSTRUCTIONS MAY RESULT IN PRODUCT DAMAGE, PROPERTY DAMAGE, PERSONAL INJURY, OR EVEN DEATH.

- Hayward Flow Control (Hayward), a division of Hayward Industries, guarantees its products against defective material and workmanship only. Hayward assumes no responsibility for property damage or personal injury resulting from improper installation, misapplication, or abuse of any product.
- Hayward assumes no responsibility for property damage or personal injury resulting from chemical incompatibility between its products and the process fluids to which they are exposed. Determining whether a particular PVC, CPVC, or PP product is suitable for an application is the responsibility of the user. Chemical compatibility charts provided in Hayward literature are based on ambient temperatures of 70°F and are for reference only.
- Hayward products are designed for use with non-compressible liquids.

WARNING

Hayward PVC and CPVC products should NEVER be used or tested with compressible fluids such as compressed air or nitrogen. Use of PVC and CPVC products in compressible fluid applications may result in product damage, property damage, personal injury, or even death.

WARNING

The TB Series Ball Valve is intended for use in liquid service only. Do not attempt to use this valve for controlling air or gases. Use of this product in air or gas service may result in product damage, property damage, personal injury, or even death.

- The maximum recommended fluid velocity through any Hayward product is eight feet per second (8 ft/s). Higher fluid velocity can result in damage due to the water hammer effect.
- Piping systems must be designed and supported to prevent excess mechanical loading on Hayward products due to system misalignment, weight, shock, vibration, and the effects of thermal expansion and contraction.
- The effect of temperature on plastic piping systems must be considered when the systems are initially designed. The pressure rating of plastic systems must be reduced with increasing temperature. Maximum operating pressure is dependent upon material selection as well as operating temperature. Before installing any Hayward product, consult Hayward product literature for pressure vs. temperature curves to determine any operating pressure or temperature limitations.
- PVC and CPVC plastic products become brittle below 40°F. Use caution in their installation and operation below this temperature.

WARNING

Hayward PVC and CPVC products should not be used in services with operating temperature below 34°F.

- Due to differential thermal expansion rates between metal and plastic, transmittal of pipe vibration and pipe loading forces, **DIRECT INSTALLATION OF PLASTIC VALVES INTO METAL PIPING SYSTEMS IS NOT RECOMMENDED.** Wherever installation of plastic valves into metal piping systems is necessary, it is recommended that at least 10 pipe diameters in length of plastic pipe be installed upstream and downstream of the plastic valve to compensate for the factors mentioned above.
- Published operating requirements are based on testing of new valves using clean water at 70°F. Valve performance is affected by many factors including fluid chemistry, viscosity, specific gravity, flow rate, and temperature. These should be considered when sizing Hayward products.
- Systems should always be depressurized and drained prior to installing or maintaining any Hayward product.

WARNING

Failure to depressurize and drain system prior to installing or maintaining valve may result in product damage, property damage, personal injury, or even death.

- Always follow your site and/or company procedures for any safety training and/or site-specific precautions or warnings in addition to those in this document.

1. INSTALLATION:

1.1. Transporting the Valve:

- 1.1.1. Valve should be stored inside factory packaging until product is ready to be installed. Packaged valve should be stored indoors, at room temperature, and out of direct sunlight. Avoid storing packaged valve in location where packaging may become wet. Valve should be moved as close to installation site as possible prior to removing from packaging. Do not cut through tape on box any more than necessary to avoid damaging valve. After removing valve from carton, care must be taken not to damage valve or to allow debris to enter valve.

WARNING

System must be depressurized and drained prior to installing valve or performing maintenance. Failure to depressurize and drain system prior to installing or maintaining valve may result in product damage, property damage, personal injury, or even death.

CAUTIONS

- Do not install valve directly to pump outlet. Allow a length of at least 5 pipe diameters between pump outlet and valve.
- Do not install valve directly after a reducer / expansion fitting. Install at least 5 pipe diameters from an expansion or reducing fitting.
- Pipe must be supported upstream and downstream of the valve. Sound piping system design principles should be applied when installing this valve.
- Do not install valve directly into a metal system. Wherever installation of thermoplastic valves into metal piping systems is necessary, it is recommended that at least 10 pipe diameters in length of thermoplastic pipe be installed upstream and downstream of the thermoplastic valve. When lifting valve do not lift by the handle.

WARRANTY TERMS AND CONDITIONS:

THREE YEAR WARRANTY: All products manufactured by Hayward are warranted against defects in material or workmanship for a period of three years from date of shipment. Our sole obligation under this warranty is to repair or replace, at our option, any product or any part or parts thereof found to be defective. HAYWARD MAKES NO OTHER REPRESENTATION OR WARRANTY, EXPRESS OR IMPLIED, INCLUDING, BUT NOT LIMITED TO, ANY IMPLIED WARRANTY OF MERCHANTABILITY OR FITNESS FOR A PARTICULAR PURPOSE. The warranty set forth above is the only warranty applicable to Hayward products and in no event shall Hayward be liable for any delay, work stoppage, cartage, shipping, loss of use of equipment, loss of time, inconvenience, loss of profits of any direct or indirect incidental resulting from or attributable to a breach of warranty. The remedies under this warranty shall be the only remedies available. OUR MAXIMUM LIABILITY SHALL NOT IN ANY EVENT EXCEED THE CONTRACT PRICE FOR THE PRODUCT.

NOTES:

Krytox™ is a trademark of The Chemours Company

To locate this IOM online please scan this QR Code.



1.2. Installing the Valve into a System:

NOTES

Hayward TB Series ball valves with standard balls are bi-directional. There are no direction arrows or specific orientation requirements for proper operation. Hayward TB & TB-Z Series ball valves with vented balls, or 'drilled balls', are uni-directional. There is a flow arrow marked on the valve to indicate proper flow direction.

- 1.2.1. Remove valve from packaging.
- 1.2.2. Verify that product is defect free and meets specifications.
- 1.2.3. Remove the nut and end connector by rotating the nuts counterclockwise. Verify end connector o-rings are installed in their respective grooves.
- 1.2.4. Place nut over pipe end so that it can engage the end connector once the end connector is connected to the pipe end.
 - 1.2.4.1. Threaded End Connectors:
 - 1.2.4.1.1. Wrap male threads of pipe end with PTFE tape. Proper application of PTFE tape will provide a sufficient seal for PVC, GFPP, and CPVC threaded joints.

WARNING

Do not use "pipe dope", liquid sealant, or thread sealant on any PVC or CPVC threaded connections. Pipe dope and thread sealants may react with the PVC or CPVC, weakening the material and potentially resulting in failure of the joint, product damage, property damage, personal injury, or even death.

- 1.2.4.1.2. Thread the end connector onto the threaded pipe end until "hand tight". Using a strap wrench only (never use a pipe wrench), tighten the end connector onto the pipe only to the point required to form a seal between the end connector and pipe thread; 1/2 turn past hand tight is typically sufficient to form a seal. (Caution: Tightening beyond this point may introduce excessive stress that could cause failure of the end connector or the threaded end of the pipe.)
- 1.2.4.2. Solvent-Weld End Connectors (PVC and CPVC only):

CAUTION

Valve center cartridge must be disassembled from nuts and end connectors prior to solvent cementing end connections into system. Avoid exposing valve cartridge and end connector o-rings to primer, solvent cement, or their fumes, as damage to the valve could result.

- 1.2.4.2.1. Refer to solvent-cement manufacturer's instructions and cure times.
- 1.2.4.2.2. Do not install valve cartridge until solvent cement has fully cured. Reinstall end connectors by threading nuts onto body by rotating in a clockwise direction.
- 1.2.4.3. Flange Connections:
 - 1.2.4.3.1. NOTE: When provided with flanges, TB Series True Union Ball Valves are provided with an end connection sub-assembly, consisting of an end connector, solvent cemented or threaded to a flange, with an assembly nut for connection to the valve.
 - 1.2.4.3.2. Flange bolts should be tight enough to compress the gasket and make a good seal, without distorting or putting excessive stress on the flanges. Suitable washers should be used between the bolt head and flange and the nut and flange. Bolts should be tightened in alternating sequence (Figure 1). See Table 1 for recommended torque.

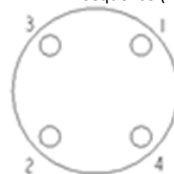

Fig. 1: Bolt Tightening Sequence

Table 1: Recommended Flange Bolt Torque

| Flange Size | Bolt Dia. (in.) | Torque (ft. lbs.) |
|-------------|-----------------|-------------------|
| 1/2" | 1/2 | 10 – 15 |
| 3/4" | 1/2 | 10 – 15 |
| 1" | 1/2 | 10 – 15 |
| 1-1/4" | 1/2 | 10 – 15 |
| 1-1/2" | 1/2 | 10 – 15 |
| 2" | 5/8 | 15 – 20 |

- 1.2.5. Install valve cartridge between end connectors, match nuts to body threads and turn nut clockwise to thread onto body. Using a strap wrench only (never use a pipe wrench), nut can be tightened 1/4 - 1/2 turn past hand-tight, as needed.
 - 1.2.5.1. Never install valve into system where assembly nuts have to be used to pull system together. This will apply undue loading on the valve body and assembly nuts. Piping system should be properly aligned prior to valve installation.
 - 1.2.5.2. Never install valve into system that must be forcibly separated to allow space for body. This will apply undue loading on the valve body.
- 1.2.6. Valve with actuator:
 - 1.2.6.1. If the valve was provided with an actuator from Hayward, the actuator stops will already be set by the Hayward during assembly.
 - 1.2.6.2. Support weight of actuator as necessary.
 - 1.2.6.3. Do not allow valve to support the weight of the pipe.
 - 1.2.6.4. When using pneumatic or electric actuators, additional support directly to the actuator is recommended. When large actuation is used, weight of the actuator needs to be supported independent of the support given by the mounting flange of the valve.
 - 1.2.6.5. Refer to IOM provided with actuator for wiring / plumbing and operating instructions.

2. STARTUP AND OPERATION:

WARNINGS

Hayward PVC and CPVC products should NEVER be used or tested with compressible fluids such as compressed air or nitrogen. Use of PVC and CPVC products in compressible fluid applications may result in product damage, property damage, personal injury, or even death. The TB Series Ball Valve is intended for use in liquid service only. Do not attempt to use this valve for controlling air or gases. Use of this product in air or gas service may result in product damage, property damage, personal injury, or even death. Hayward PVC and CPVC products should not be used in services with operating temperature below 34°F.

- 2.1. Operate valve to 45° (i.e. ½ open) position.
- 2.2. Slowly purge air from the system as line fills with liquid.
- 2.3. Look for leaks around valve handle, stem, and end connections and check for proper valve operation. If any leaks are present, or valve does not perform properly, refer to troubleshooting guide. Depressurize and drain system prior to performing any maintenance.
- 2.4. Periodically check valve for leaks or external damage.
- 2.5. Periodically check true union nuts and / or flange connections.
- 2.6. **Operation of valve to full closed:**
 - 2.6.1. Rotate the handle clockwise about stem axis to close.
 - 2.6.1.1. When fully closed, the handle will be perpendicular to pipe axis / centerline.
- 2.7. **Operation of valve to full open:**
 - 2.7.1. Rotate the handle counterclockwise about stem axis to open.
 - 2.7.1.1. When fully open, the handle will be parallel to pipe axis / centerline.
- 2.8. Periodic Operation
 - 2.8.1. Where possible, for valves installed in locations where they are not operated frequently, it is recommended that valves are operated according to a routine maintenance schedule at least once every six months.

3. MAINTENANCE:

WARNINGS

System must be depressurized and drained prior to installing valve or performing maintenance. Failure to depressurize and drain system prior to installing or maintaining valve may result in product damage, property damage, personal injury, or even death.

Make sure operator or actuator, if any, has no stored energy and is in its fail position if applicable. For valves supplied with electric actuators, follow lock out/tag out procedures and remove all power from device before performing maintenance.

Valve must only be removed from line when handle is in partially, but not fully, open position (i.e. 45° position) and when line is fully depressurized and drained. Valves that are in fully open or fully closed positions could have trapped cavity pressure.

- 3.1. **Replacing End Connector O-Rings:**
 - 3.1.1. Depressurize and drain system with valve handle in partially, but not fully, open position (i.e. handle at 45° position).
 - 3.1.2. Remove assembly nuts from valve body by rotating counterclockwise.
 - 3.1.3. Remove valve body from system.
 - 3.1.4. Using a plastic pick, carefully remove the old O-rings. NOTE: Be very careful not to damage the o-ring grooves or valve body.
 - 3.1.5. Clean o-ring grooves with a soft brush or cloth.
 - 3.1.6. Install new o-rings by gently pressing o-ring into groove until o-ring is fully seated.
 - 3.1.7. Install valve cartridge between end connectors, match nuts to body threads and turn nut clockwise to thread onto body. Using a strap wrench only (never use a pipe wrench), nut can be tightened ¼ - ½ turn past hand-tight, as needed.
 - 3.1.7.1. Never install valve into a system where assembly nuts have to be used to pull system together. This will apply undue loading on the valve body and assembly nuts. The piping system should be properly aligned prior to valve installation.
 - 3.1.7.2. Never install valve into a system that must be forcibly separated to allow space for body. This will apply undue loading on the valve body
- 3.2. **Removing Handle:**
 - 3.2.1. Depressurize and drain system with valve handle in partially, but not fully, open position (i.e., handle at 45° position).
 - 3.2.2. The handle can be removed by pulling it away from the valve. It is lightly press fitted to the stem.
- 3.3. **Replacing Internal Seats and Seals:**
 - 3.3.1. Depressurize and drain system with valve handle in partially, but not fully, open position (i.e. handle at 45° position).
 - 3.3.2. Remove assembly nuts from valve body by rotating counterclockwise.
 - 3.3.3. Remove valve body from system.
 - 3.3.4. Rotate handle so valve is in fully closed position.
 - 3.3.5. Remove handle (See Section 3.1)
 - 3.3.6. Remove seal retainer from body by using the tool, TBSRW. Note the thread on the ¼" -2" valves is a right hand thread. The tool is available from your Hayward distributor.
 - 3.3.7. Remove ball from body by reaching inside closed end bore of body and pushing ball towards open end of valve body.
 - 3.3.8. Remove stem from body by pressing on top of stem and forcing stem into body, then pulling stem out of body.
 - 3.3.9. Using a plastic pick, remove the O-rings from the stem, body end, and seal retainer. Note O-ring size for each location.
 - 3.3.10. Using a plastic pick, remove seats from the seal retainer and body.
 - 3.3.11. Clean O-ring grooves and seat pockets with a soft brush or cloth.
 - 3.3.12. Install and lightly lubricate new O-rings on stem. Be careful not to roll or damage O-rings during installation. Hayward recommends lubricating O-rings with Krytox™ GPL203.
 - 3.3.13. Install seat into the body.
 - 3.3.13.1. NOTE: Seat is reversible and can be installed with either side facing towards ball.
 - 3.3.14. Install stem into stem bore by rotating stem inside valve body until center axis of stem is aligned with stem bore, then pressing gently and evenly on stem until stem has "bottomed" against the body stem counterbore.
 - 3.3.15. Install handle onto stem.
 - 3.3.16. Make certain that handle-stem assembly is rotated to the closed position.
 - 3.3.17. Install ball into body in closed position. Make certain ball slot engages bottom stem boss.
 - 3.3.18. Insert a seat in the seal retainer.
 - 3.3.19. Install seal retainer-seat assembly to valve by threading seal retainer into body and rotating clockwise until the seat contacts the ball. The seal retainer allows adjustment of the seat to ball contact. Tighten the seal retainer until the expected valve operating torque is achieved.
 - 3.3.20. Install new end connector O-rings into body and seal retainer by gently pressing O-ring into groove until O-ring is fully seated.
 - 3.3.21. Reinstall valve body into system per Section 1.2.5.
 - 3.3.22. Restart system per Section 2.0

4. PRODUCT SPECIFICATIONS:

Maximum Pressure: 250 psi @ 70°F PVC and CPVC, 150 psi @ 70°F GFPP, (see Chart 1 for operating pressures at elevated temperatures)

Operating Temperature:

| Material | Min. Operating Temperature | Max. Operating Temperature |
|----------|----------------------------|----------------------------|
| PVC | 34°F (1.1°C) | 140°F (60.0°C) |
| CPVC | 34°F (1.1°C) | 190°F (82.2°C) |
| GFPP | 20°F (-6.6°C) | 240°F (115°C) |

Max. System Flow Velocity:

8 ft/s (2.4 m/s) for thermoplastic piping systems

Flow Coefficient, TB:

| Opening Angle | 1/4" | 3/8" | 1/2" | 3/4" | 1" | 1-¼" | 1-½" | 2" |
|---------------|------|------|------|------|------|------|------|-----|
| 90° | 1.0 | 2.8 | 8.0 | 16.0 | 29.0 | 75.0 | 90.0 | 150 |

WARNING

The maximum recommended fluid velocity through any plastic piping system is eight feet per second (8 ft/s). Higher fluid velocity can create excess water hammer effect, resulting in property damage, personal injury, or even death.

CAUTION

Published operating requirements are based on testing of new valves using clean water at 70°F. Valve performance is affected by many factors including fluid chemistry, viscosity, specific gravity, flow rate, and temperature. These should be considered when sizing systems using Hayward products.

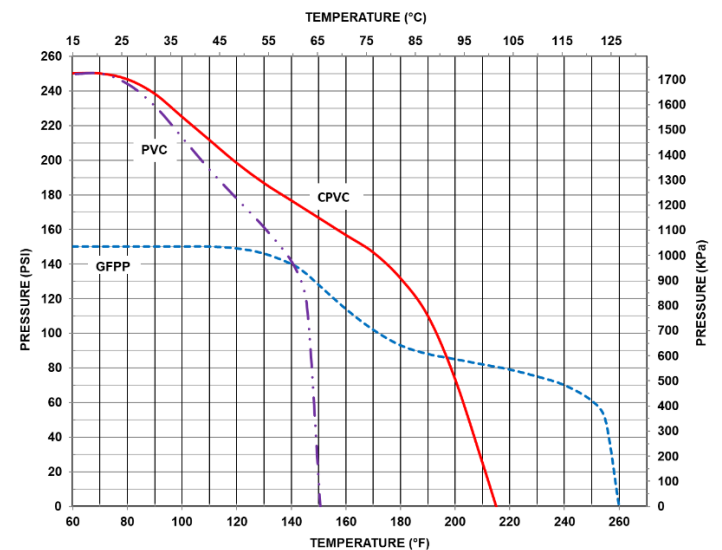

Chart 1: Operating Pressures at Elevated Temperatures

5. PARTS LIST:

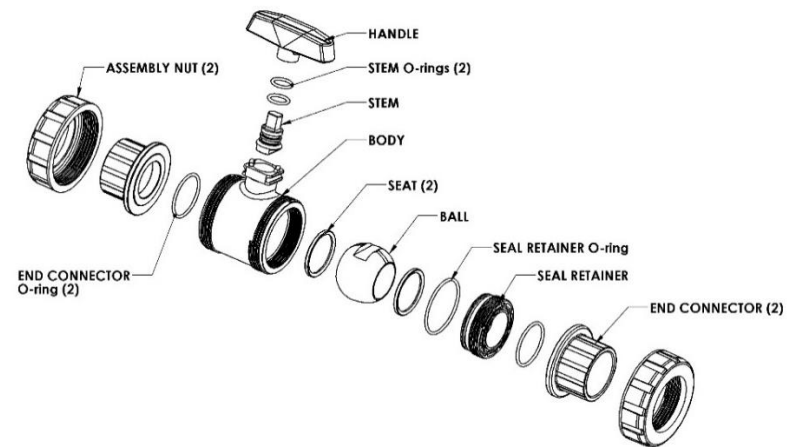

Fig. 2: Exploded View of TB Series Ball Valve

Authorised Distributor of Hayward Flow Control, a Division of Hayward Industries, Inc

Hayward Flow Control has been a leading manufacturer of industrial thermoplastic valves and process control products for more than 60 years. In fact, Hayward was one of the originators of the first thermoplastic ball valves. Since then, we have remained committed to producing the highest quality products while providing outstanding service.

Liquid Filters and Strainers



Bag Filter vessel

- GFPP
- PVC
- CPVC



Y Strainers

- PVC
- CPVC
- Clear PVC
- PVDF



Simplex Strainers

- PVC
- CPVC
- GFPP
- PVDF
- Eastar® (Clear)



Duplex Strainers

- PVC
- CPVC
- GFPP
- Eastar® (Clear)

Valves and Flow Control



Ball Valves

- PVC
- CPVC
- GFPP
- PVDF



Check Valves

- Ball Check Valves
- Y-Check Valves
- Wafer Check Valves
- Swing Check Valves



Pressure & Chemfeed

- Injection Quills
- Back Pressure
- Pressure Relief
- Diaphragm Valves
- Needle Valves
- Angle Globe Valves



Butterfly Valves

- PVC
- CPVC
- GFPP
- PP
- PVDF



Actuation

- Electric
- Pneumatic



Solenoid Valves

- PVC
- CPVC
- PVDF



Australia

Monarch Asia Pacific Pty Ltd
Unit 3
8 Bult Drive
Brendale, QLD 4500

Phone : +61 (0) 7 3889 9949

www.monarcindustrial.com.au



Thailand

PSF Equipment (Thailand) Co Ltd
11 Soi Suanphak 42
Suanphak Road, Chimphi
Talingchan, Bangkok 10170

Phone : +66 (0) 2 882 5512
Fax No: +66 (0) 2 424 3725

www.psfthailand.com