

Model 53BTX

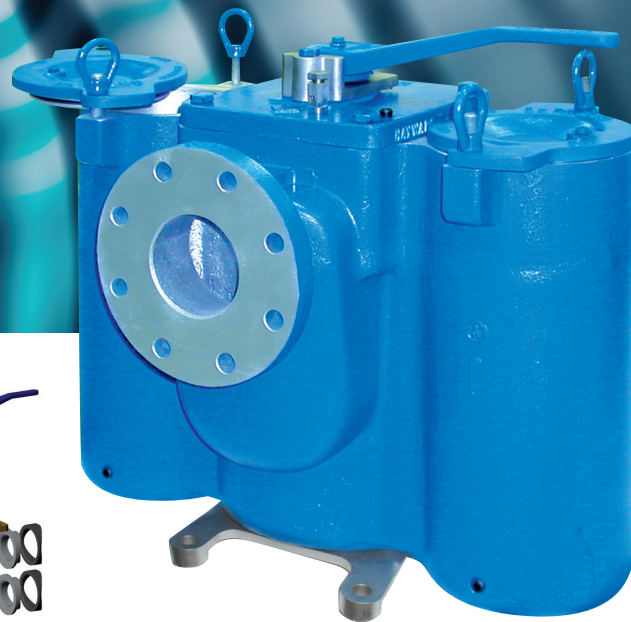

- Sizes 3/4" to 4"
- Iron, bronze, carbon steel or stainless steel
- Threaded or flanged

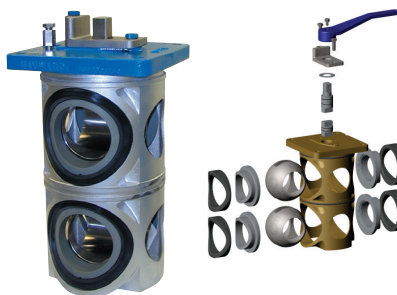

Unique diverter cartridge assures leak-tight isolation of basket chamber during cleaning.

A double sealing system on the upper and lower stems guards against any possible leakage. If service becomes necessary, just remove four bolts and the cartridge slides right out the top of the strainer body.

Features

- Dynamic sealing design for long life
- Easy-to-operate lever handle—no gear box required
- Unique seat and seal design requires no adjustments
- Teflon® seats for longer service life
- Foot pads for rock solid installation
- Double-stem O-rings for positive sealing
- Easy to access body vent valve
- Drain plugs in each basket cover
- Piston seal strainer basket cover
- Easy access for diverter cartridge removal
- 316 stainless steel ball design
- American Bureau of Shipping (ABS) Type Approved for ship designers, builders and owners

Teflon® and Viton® are registered trademarks of E. I. du Pont de Nemours and company. MONEL® is a registered trademark of Special Metals Corporation group of Companies. HASTELLOY® is a registered trademark of Haynes International Inc.



Brisbane, Australia

www.monarchindustrial.com.au

www.monarchasiapacific.com.au

Continuous operation

The Eaton Model 53BTX duplex basket strainer can operate continuously, eliminating the need to shut down processes for cleaning of strainers. When the first basket is full, a unique flow diverter cartridge shifts flow to a second basket to permit removal and cleaning with no interruption to operations.

Draining this chamber is easy; the cover lifts and swings clear of the chamber opening with no special tools required.

The unique flow diverter cartridge prevents fluid bypass into the out-of-service chamber. It features a dynamic sealing system that ensures exceptionally long seat life and positive sealing. Manual internal or external ball support adjustments are not necessary.

Size and material

The compact, low-profile Model 53BTX fits into spaces ordinary strainers may not, yet it still uses full-size strainer baskets with a low-pressure drop performance. Eaton offers basket openings from 3/4" down to 45 microns. Type 316 stainless steel is standard and MONEL® or HASTELLOY® C materials are optional.

Easy basket servicing

One drain plug is on each side of the housing. Additionally, an easy to access vent valve is in the cover. Standard foot mounting pads ensure a rock solid installation no matter where the strainer operates.

Available options include:

- Differential pressure gauges, with or without switches
- Magnetic separators installed in the strainer basket for removing fine ferrous particulate matter from the process media

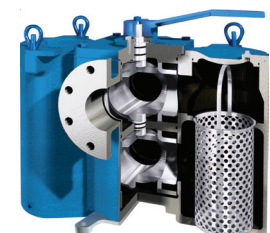

Model 53BTX Ball Type Duplex Basket Strainer

Selection table

Size	Body & cartridge material	End connection	Seat/Seal	Diverter balls	Pressure rating @ 150 °F (65 °C)
3/4", 1", 1-1/4", 1-1/2", 2", 2-1/2"	Iron	Threaded	TFE/Buna-N®*	Stainless steel	200 psi (13.8 bar)
3/4", 1", 1-1/4", 1-1/2", 2", 2-1/2"	Bronze	Threaded	TFE/Buna-N*	Stainless steel	200 psi (13.8 bar)
3/4", 1", 1-1/4", 1-1/2", 2"	Carbon steel	Threaded	TFE/Buna-N*	Stainless steel	200 psi (13.8 bar)
3/4", 1", 1-1/4", 1-1/2", 2"	Stainless steel	Threaded	TFE/Viton®	Stainless steel	200 psi (13.8 bar)
1", 1-1/2", 2", 2-1/2", 3", 4"	Iron	Flanged 125#	TFE/Buna-N*	Stainless steel	200 psi (13.8 bar)
1", 1-1/2", 2", 2-1/2", 3", 4"	Bronze	Flanged 150#	TFE/Buna-N*	Stainless steel	200 psi (13.8 bar)
1", 1-1/2", 2", 2-1/2", 3", 4"	Carbon steel	Flanged 150#	TFE/Buna-N*	Stainless steel	200 psi (13.8 bar)
1", 1-1/2", 2", 2-1/2", 3", 4"	Stainless steel	Flanged 150#	TFE/Viton	Stainless steel	200 psi (13.8 bar)

*Viton standard for SSTL, optional for iron, bronze and carbon steel.

Cy factors*

Size	Value	Size	Value
3/4"	13	2"	42
1"	13	2-1/2"	65
1-1/4"	18	3"	110
1-1/2"	25	4"	175

* For water with clean, perforated basket

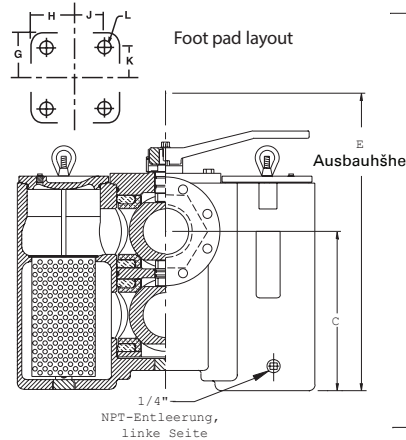
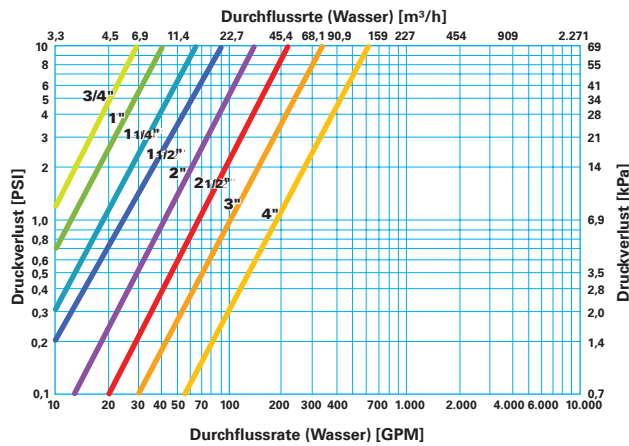

Front view flanged and threaded models

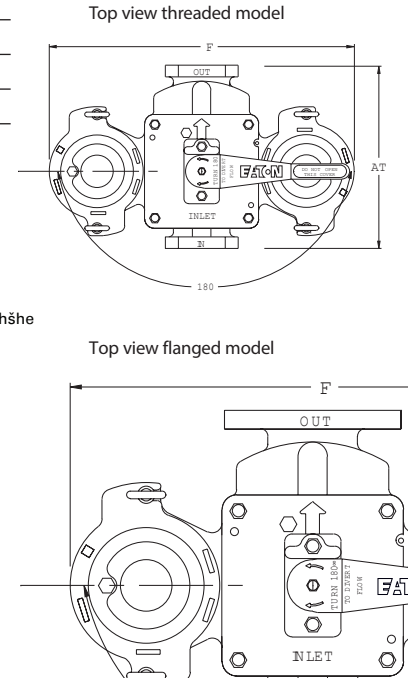

Dimensions (in/mm)

Pipe size	AF		AT		C		E		F		G		H		J		K		L		Weight - Iron flanged (lb / kg)		Weight - Bronze flanged (lb / kg)		Weight - Carbon & SS flanged (lb / kg)	
	in	mm	in	mm	in	mm	in	mm	in	mm	in	mm	in	mm	in	mm	in	mm	in	mm	in	mm	in	mm	in	mm
3/4"	—	—	5.50 / 140	5.00 / 127	5.00 / 127	13.38 / 340	10.50 / 268	3.25 / 83	2.13 / 54	1.63 / 41	2.75 / 70	3/8	—	37 / 17	—	46 / 21	—	41 / 19	—	—	—	—	—	—	—	—
1"	6.88 / 175	5.50 / 140	5.00 / 127	13.38 / 340	10.50 / 268	3.25 / 83	2.13 / 54	1.63 / 41	2.75 / 70	3/8	42 / 19	37 / 17	52 / 24	46 / 21	47 / 21	41 / 19	—	—	—	—	—	—	—	—	—	—
1-1/4"	6.88 / 175	7.50 / 190	6.81 / 173	17.00 / 432	13.25 / 330	3.25 / 83	2.13 / 54	1.63 / 41	2.75 / 70	3/8	—	80 / 36	—	100 / 45	—	89 / 40	—	—	—	—	—	—	—	—	—	—
1-1/2"	9.38 / 238	7.50 / 190	6.81 / 173	17.00 / 432	13.25 / 330	3.25 / 83	2.13 / 54	1.63 / 41	2.75 / 70	3/8	90 / 41	80 / 36	113 / 51	100 / 45	100 / 45	89 / 40	—	—	—	—	—	—	—	—	—	—
2"	10.63 / 270	10.00 / 254	8.38 / 213	21.75 / 552	17.38 / 441	4.69 / 119	2.50 / 64	1.81 / 46	4.00 / 102	5/8	167 / 76	157 / 71	209 / 95	197 / 90	185 / 84	174 / 79	—	—	—	—	—	—	—	—	—	—
2-1/2"	10.75 / 273	10.00 / 254	8.38 / 213	21.75 / 552	17.37 / 441	4.69 / 119	2.50 / 64	1.81 / 46	4.00 / 102	5/8	183 / 83	157 / 71	229 / 104	197 / 90	203 / 92	—	—	—	—	—	—	—	—	—	—	—
3"	13.50 / 343	—	8.88 / 226	26.50 / 673	22.75 / 578	4.69 / 119	2.50 / 64	1.81 / 46	4.00 / 102	5/8	285 / 129	—	357 / 162	—	432 / 196	—	—	—	—	—	—	—	—	—	—	—
4"	16.00 / 406	—	13.25 / 337	33.00 / 838	24.75 / 629	5.19 / 132	3.94 / 100	3.25 / 83	4.50 / 114	5/8	389 / 177	—	487 / 221	—	432 / 196	—	—	—	—	—	—	—	—	—	—	—

Dimensions and weights are for reference only. Contact Eaton for certified drawings. Pressure equalizing valve and piping standard on 4" Model 53BTX duplex strainers.



Brisbane, Australia

www.monarchindustrial.com.au

www.monarchasiapacific.com.au



Powering Business Worldwide

US
EF-SSEA-11
7-2015

