

## Custom Strainer Basket

Monarch Asia Pacific Pty Ltd  
www.monarchindustrial.com.au

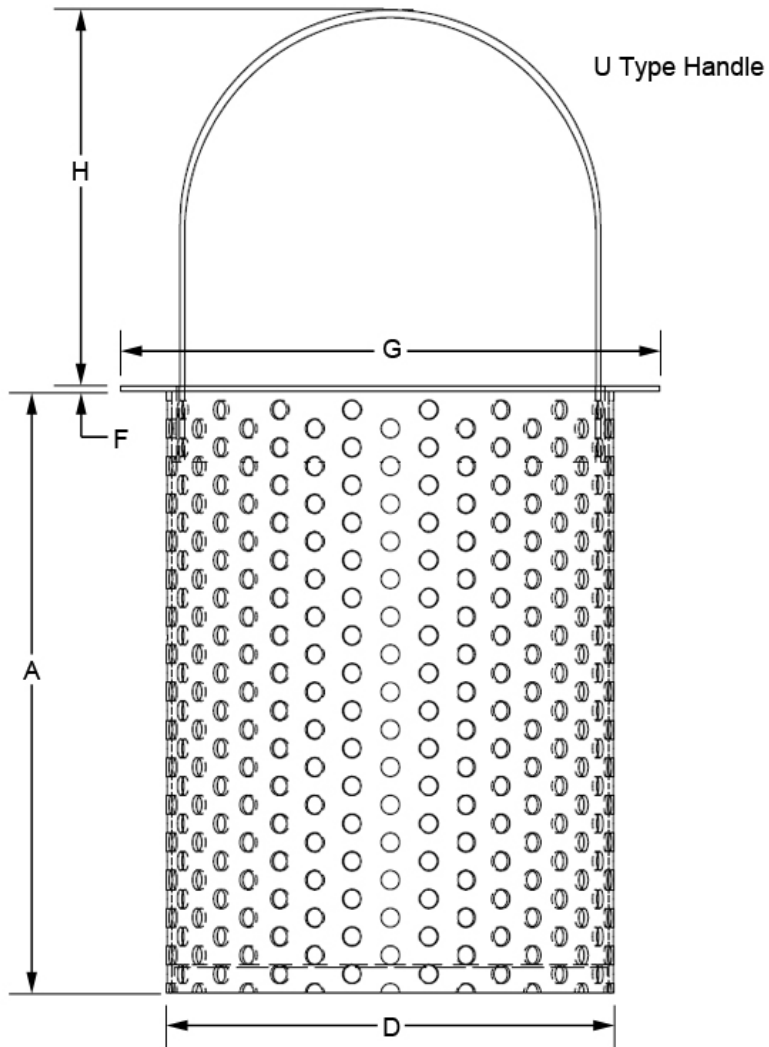

Description		Dimension (mm)
A	Height	
D	Max. Diameter	
F	Flange Thickness (optional)	
G	Flange Diameter	
Handle	<input type="checkbox"/> Not required	<input type="checkbox"/> U Type <input type="checkbox"/> Cross Rod
H	Handle Height	
<b>Perforation/Micron Size</b>		
<b>Mesh Liner size if required</b>		
<b>Material</b>	<input type="checkbox"/> 304 S/Steel	<input type="checkbox"/> 316 S/Steel
<b>No. of units required</b>		
<b>Other information</b>		

<b>Contact Name</b>	
<b>Company Name</b>	
<b>Address</b>	
<b>Phone Number</b>	
<b>Email Address</b>	
Ref No:	Date: